

Overhead Rail Scale

Model : FS8211 Series

Our robust rail scale is engineered to provide a safe and accurate overhead weighing solution in areas that require heavy duty washdown such as meat processing plants.

It features a fully galvanised frame, is legal for trade use in New Zealand and is compatible with a wide variety of weight indicators.

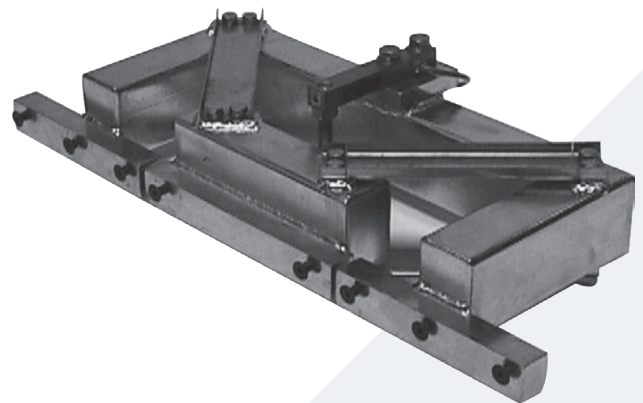
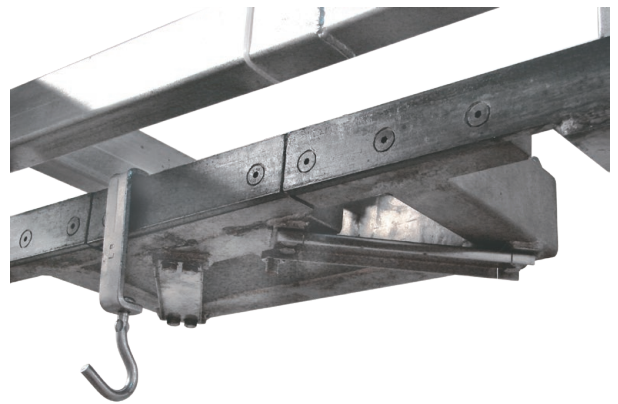

FEATURES

FS8211 SERIES

- legal for trade use (TS1039)
- trade approval applies when connected to an approved indicator
- designed and made especially for the meat processing industry
- comprises of a hermetically sealed, stainless steel loadcell for wash-down areas
- 220 mm live rail sections
- electro-galvanised protection

OPTION

- 2 loadcell version with 320 mm live rail (order code FS8221500K)*
* FS8221 can be customised to longer lengths if required

VARIATIONS

Model Number	Max Capacity	Graduation	Live Rail Size (mm)	Overall Dimensions (mm)
FS8211100K	100 kg	100 g	220 mm	600 (L) x 230 (D) x 130 (H)
FS8211200K	200 kg	200 g	220 mm	600 (L) x 230 (D) x 130 (H)
FS8211250K	250 kg	500 g	220 mm	600 (L) x 230 (D) x 130 (H)
FS8221500K	500 kg	500 g	320 mm	700 (L) x 250 (D) x 140 (H)

Specifications may change without notice