

Mini Mixer Grinder

Model: BRAFMGMINI32

Compact, powerful and ergonomically designed meat mincer mixer.

Suitable for grinding fresh meat, sausage or poultry all day, the BRAFMGMINI32 is a compact meat mincer mixer with flared hopper and powerful processing capabilities. The ergonomic design means operators don't have to lift lugs over their head or bend over to fill trays, and the smart design makes it easy to clean so you don't run the risk of cross-contamination between mixes.

FEATURES

BRAFMGMINI32

- high quality, stand alone, compact automatic feed mixer grinder with flared hopper
- 3 HP (2.2 kw) motor and size #32 head allows output up to 27 kg per minute, enhancing productivity and profitability
- 27 kg hopper takes full meat lugs
- heavy duty stainless steel tub and frame
- bowl, ring and auger are hot dipped tin
- magnetic safety interlock on tub and lid
- totally enclosed motor

SPECIFICATIONS

Plate Size:	99 mm (#32)
Hopper Capacity:	27 kg
Output:	27 kg per minute
Overall Dimensions (mm):	635 (W) x 991 (D) x 1461 (H)
Power:	3 phase 3 HP, 2.0 Kw, 415 Volts, 50 Hz
Weight:	195 kg

OPTIONS

- Pneumatic Footswitch (order code GY0799)



Specifications may change without notice

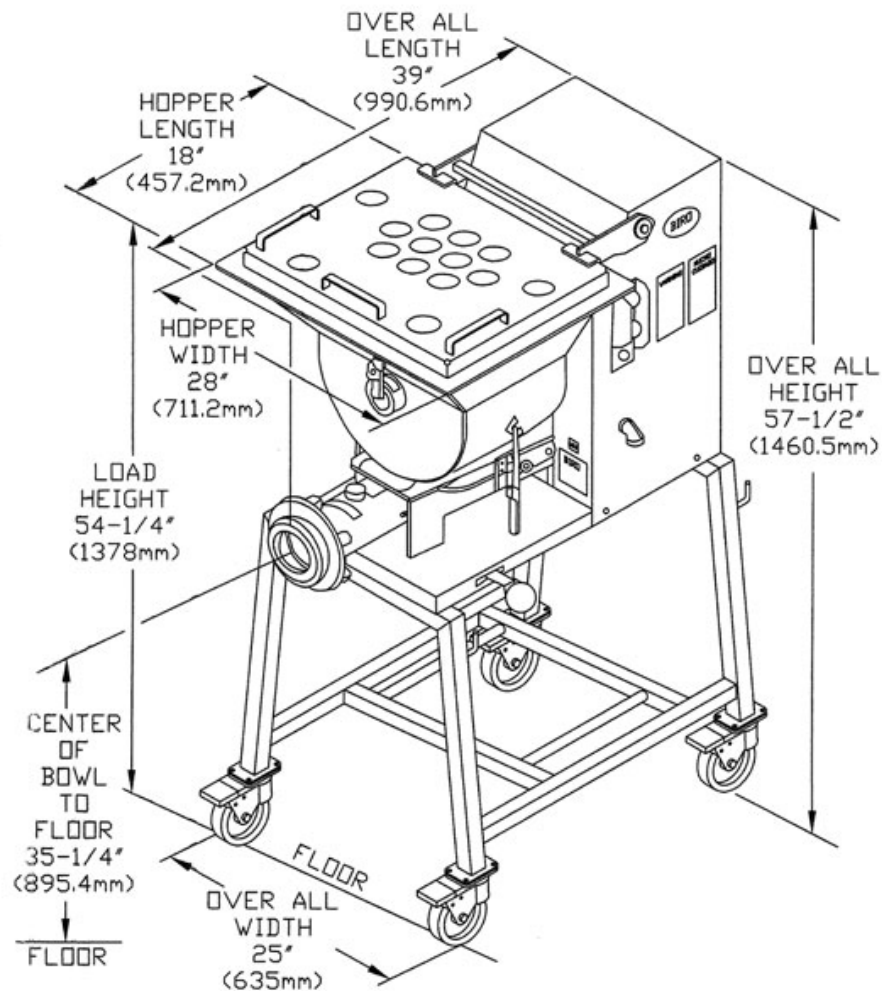

Specifications may change without notice