

In-Line Tray Sealer

Model: WFTMG2

The WFTMG2 In-Line Tray Sealer delivers an exceptionally efficient tray sealing solution ideal for high demand food packing environments. With the ability to pack two different size trays without a change of moulds, our WFTMG2 Tray Sealer really is in a class of its own. Even different depth trays aren't an issue for this Tray Sealer. Delight your customers with beautifully packaged food that looks and stays fresher for longer.

The WFTMG2 In-Line Tray Sealer can be seamlessly integrated with our TSLI-5600B2 In-Line Weigh Labeller to create a complete trade approved tray sealing weigh labelling system configured to suit your production requirements.

FEATURES

WFTMG2

- plain seal and MAP (V&G)
- ability to seal four trays at once or configured with dual moulds to seal two different tray sizes without having to change the moulds
- pack up to 64 trays per minute (speed will vary depending on the size of trays being filled and sealed, and the functionality being used)
- small footprint
- easy to use colour touch screen for operator efficiency
- film roll is easily accessible for quick and safe roll changes
- constructed from high grade stainless steel and anti-corroding aluminium
- engineered to use both recyclable trays and recyclable film

OPTIONS

- plain seal and Gas Purge (MAP) - factory fitted option
- remote machine control and support via ethernet
- SKIN pack (VSP) - factory fitted option
- quick-change mould trolley enables moulds to be changed as quickly as two minutes
- powered exit conveyor with channelizing system allows trays to be presented in single file - factory fitted option (order code WFTMG2CHANNELCON)
- automatic, trade approved weigh labeller for complete system that delivers beautifully sealed trays with multiple labels ready for the retail shelf (In-Line Weigh Labeller TSLI-5600B2)
- collection rotary table (order code # WPROTARY)



Specifications may change without notice

SPECIFICATIONS

Packaging Type	Tray Sealing
Packaging Rate	Up to 16 cycles per minute; 32 packs using two moulds, or 64 packs using four moulds at once Note: speed of packing depends on the type of trays being used and functions set, e.g. Seal Only, V&G (MAP) or SKIN (VSP)
Film Width - Maximum	430 mm
Film Diameter - Maximum	280 mm
Film Core - Maximum	75 - 80 mm
Tray Height - Maximum with Vacuum/Gas*	100 mm
Tray Height - Maximum without Vacuum/Gas*	110 mm
Operator Panel	User friendly touch screen
Power Required	400 V 3 phase + n 50 / 60 Hz, 5 Kw
Compressed Air Requirements	7 bar (100 psi) 20,000 litres / hr (12 cfm)
Vacuum Pump	100 m ³ per hour
Ingress Protection Rating	IP65
Overall Dimensions	779 (W) x 3658 (L) x 1862 (H)
Net Weight of Machine	750 kg approx

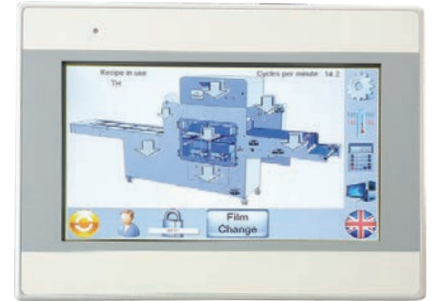

Bright colour touch screen operator panel.



Combine our WFTMG2 In-Line Tray Sealer & TS-LI5600 In-Line Weigh Labeller for a complete turnkey solution. Engineered for recyclable trays and film.

*Tray Dimensions. Maximum Height is detailed above. There are many options available for depth and width of trays as depicted in the line drawings below.

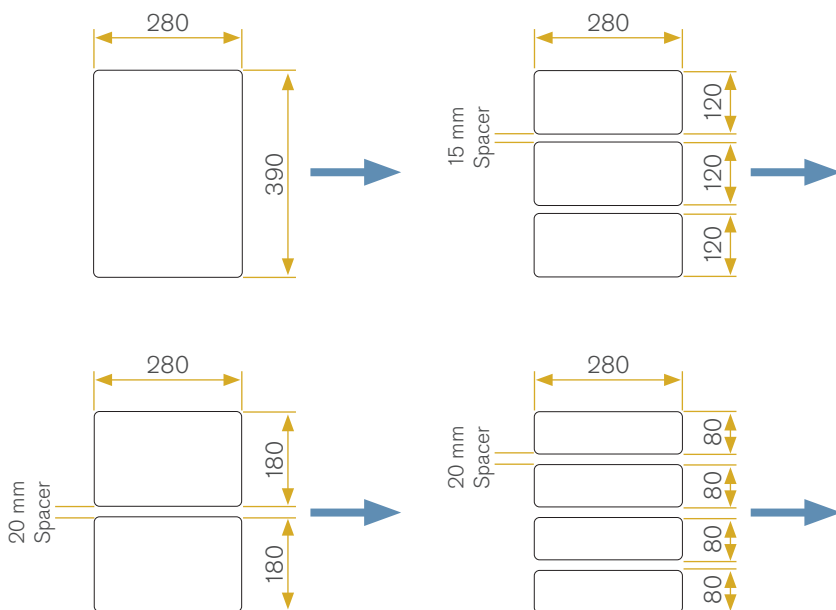

Specifications may change without notice

MACHINE DETAILS

WFTMG2

1 Electrical (EL)

Plug 32A 400V 50 / 60 Hz 3Ph+N+Pe
400 V 3 phase + n 50 / 60 Hz, 5 Kw

1 Pneumatics (PN)

Air Connection Pipe ø12
7 bar 22 litres / cycle
Max 20.000 litres / hour

1 GAS

Pipe Connection Pipe ø10

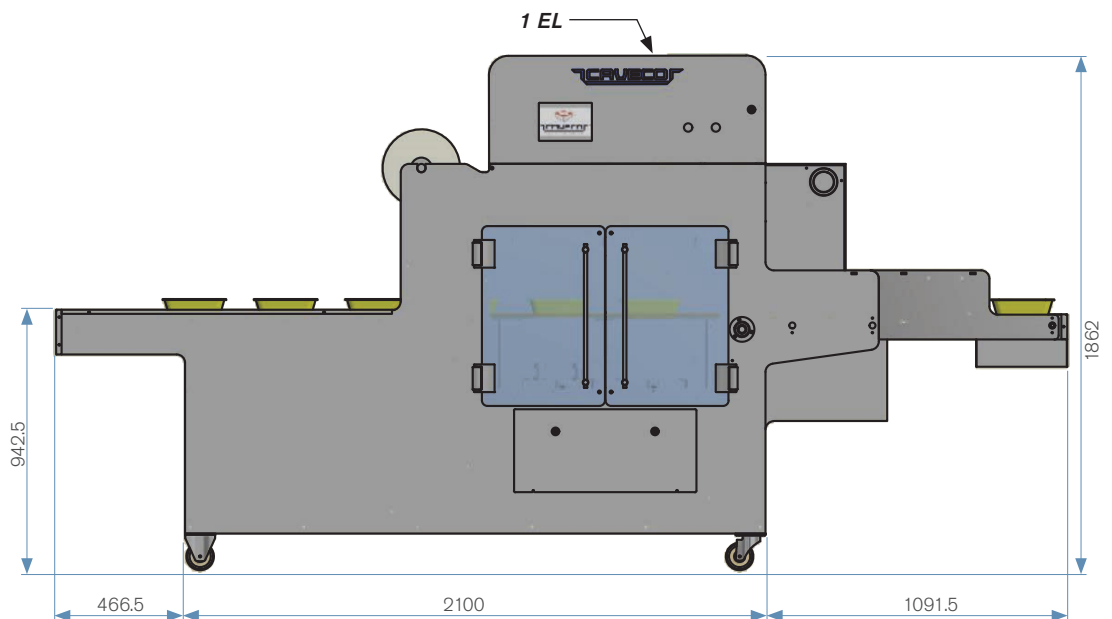
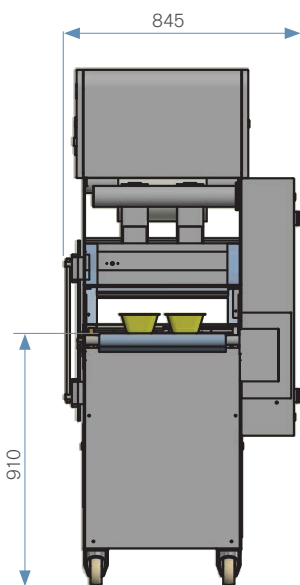
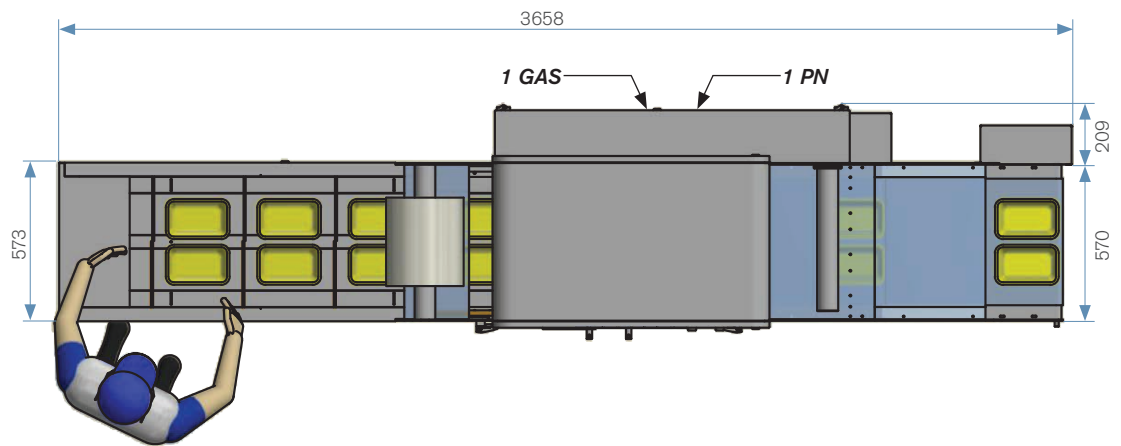
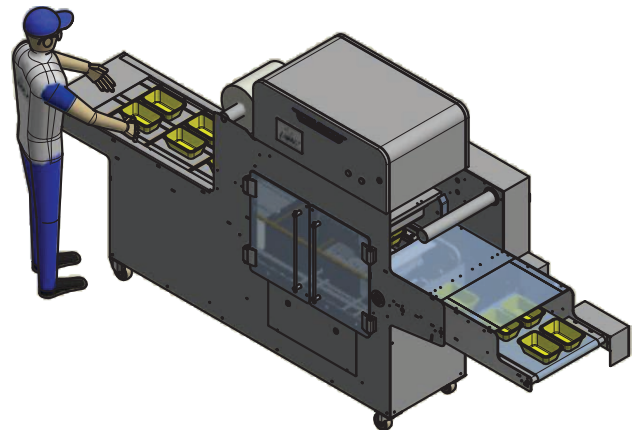

Specifications may change without notice